



iPE Exhaust

Installation manual

BMW G20 330i

Announcement

- iPE developed exhaust systems based on the OEM exhaust to avoid issue with installation.
- Modern car keys and the vehicle itself have an inductive power transmission function, we suggest to keep the car key at least 5 meters away from the vehicle for safety purpose.
- Please wear insulated gloves to replace the exhaust pipe when hot, or replace it after cool down to avoid burns.
- When setting the valve to open automatically, please do not let the valve open prematurely to avoid resonance
- It is recommended to set the timing of valve opening to 60% of the throttle.
- For detailed setting options, please refer to the control box setting page.

BMW G20 330i Product Assembly

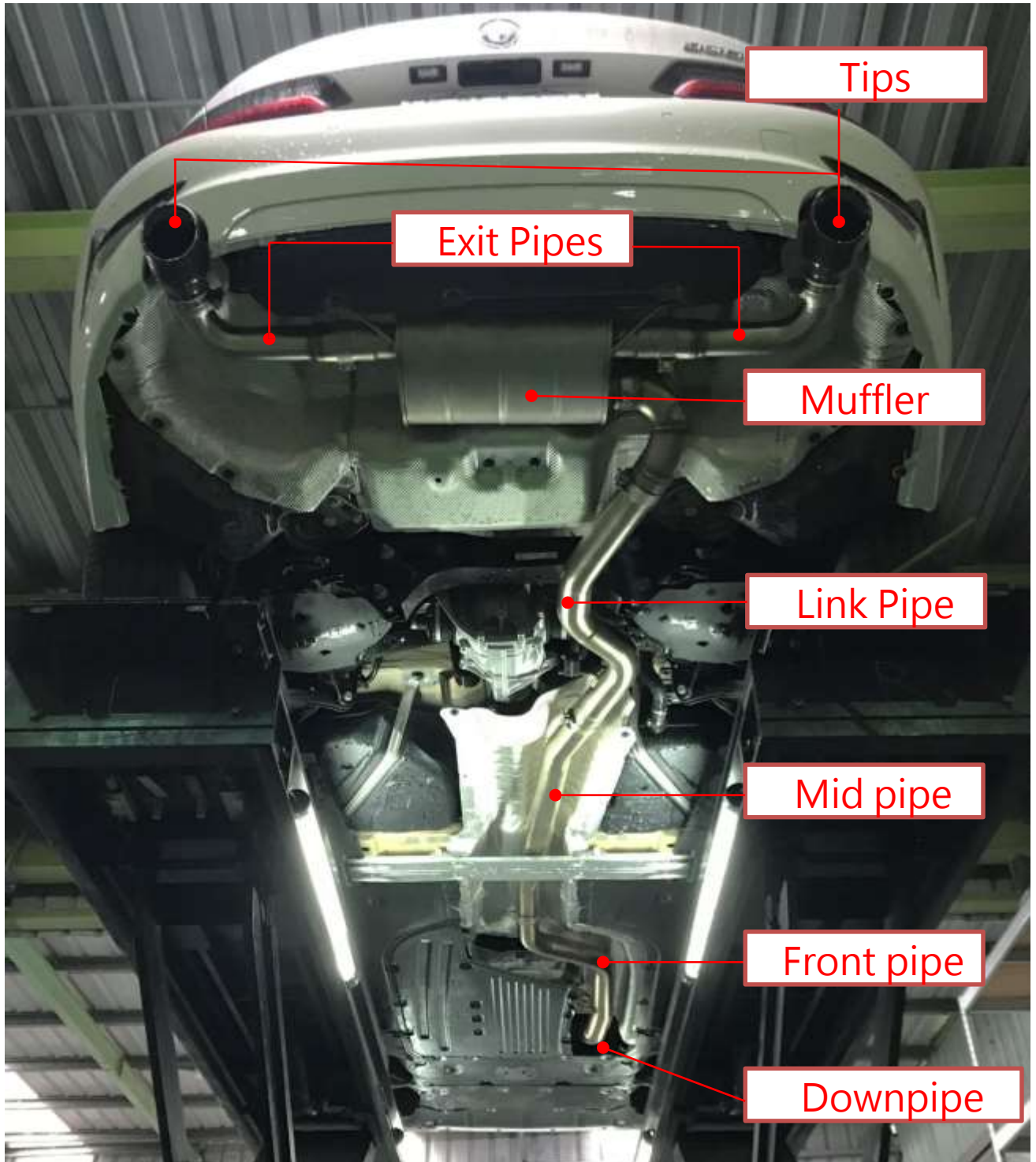

Remove the factory exhaust

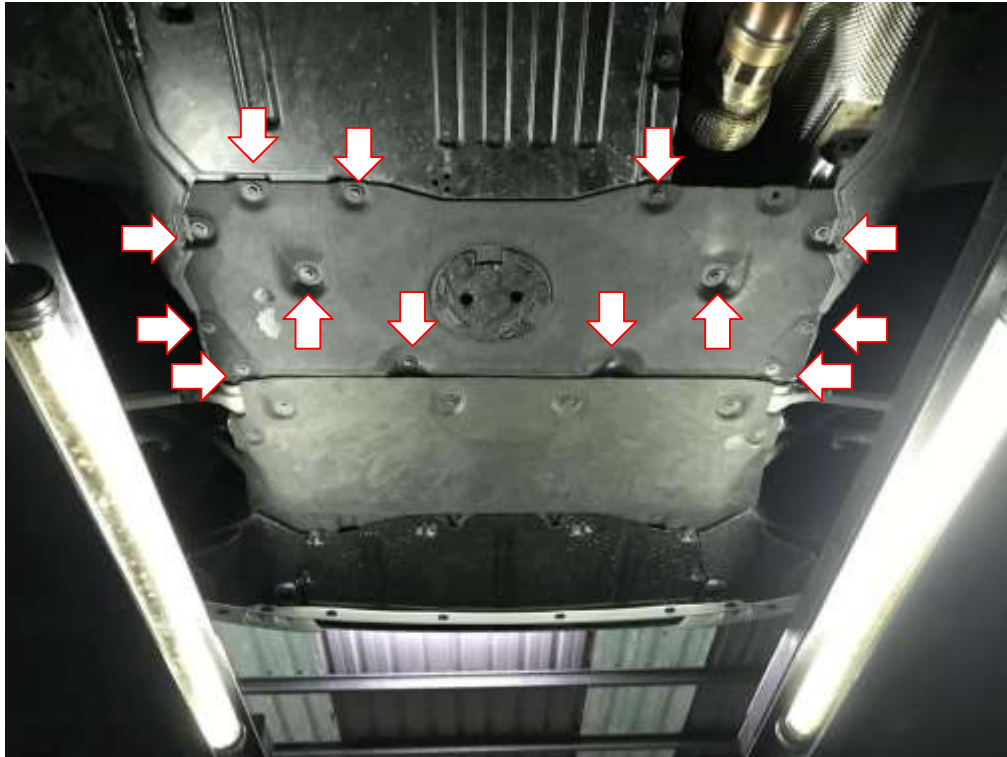

Remove the hangers and V Clamps



Remove the support brace bar

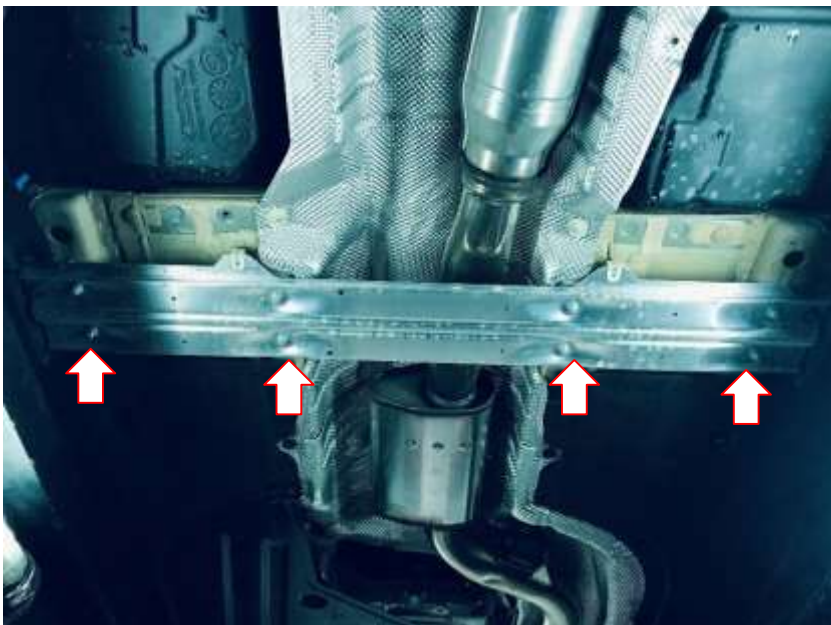

Remove the factory control valves

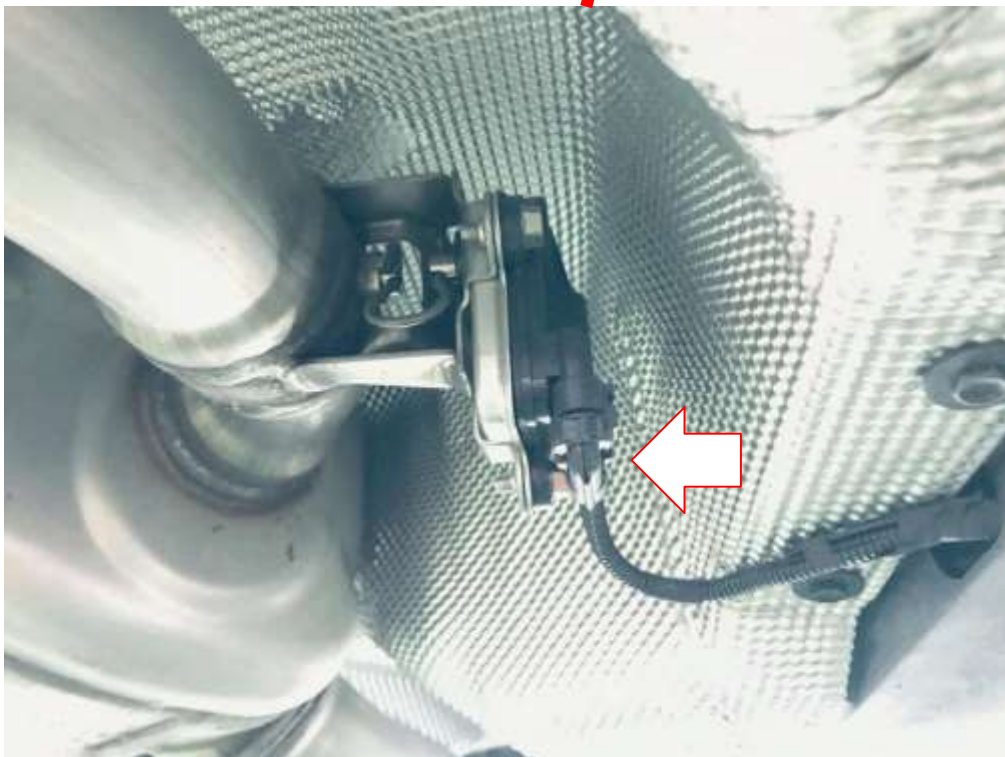

Remove the rear hangers and brackets



Remove front and rear O2 sensors



Remove V-clamps and the support screws

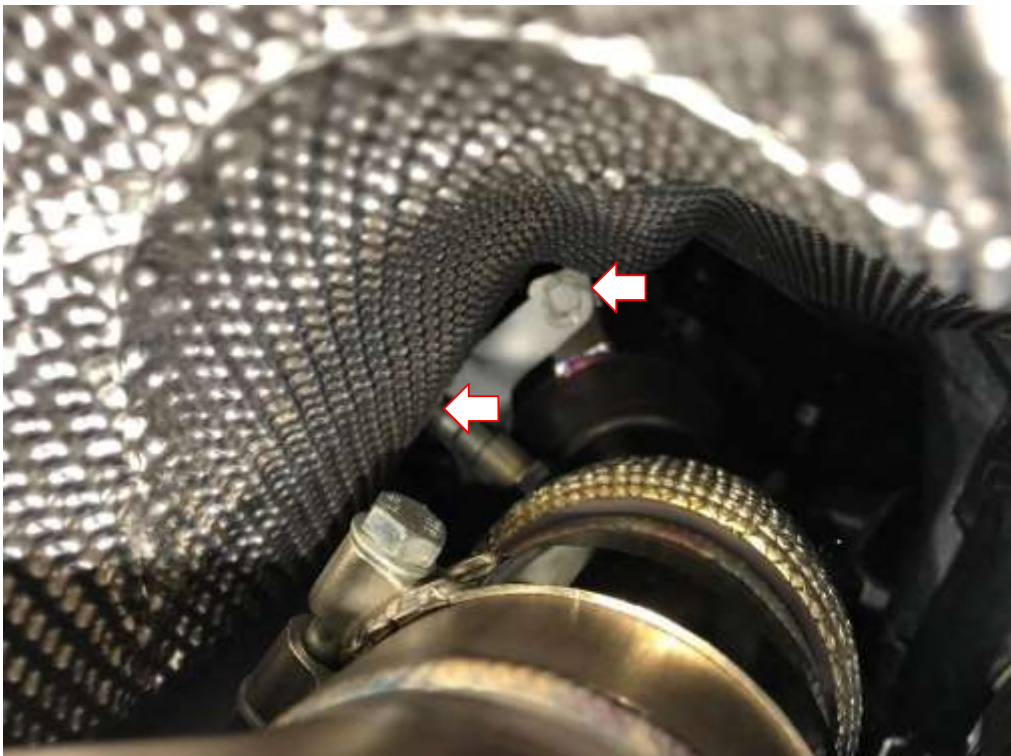

Transfer the factory downpipe gasket to iPE downpipe.



Install iPE Exhaust system

1. Put on iPE downpipe and screws first and then tight down the V-clamp.

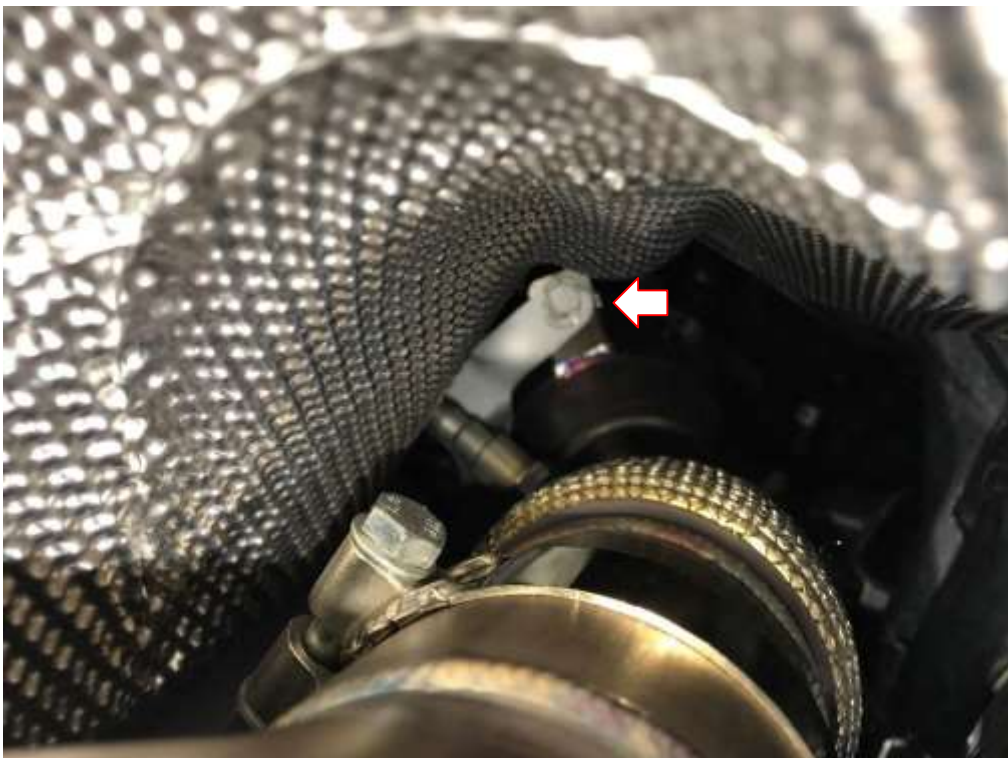

2. Assemble front and rear O2 sensors.



3. Install iPE front pipe and tight down hangers and v-clamps.



4. Install support brace bar and mid-pipe.
5. leave **at least 15mm** between the exhaust and the support brace bar.

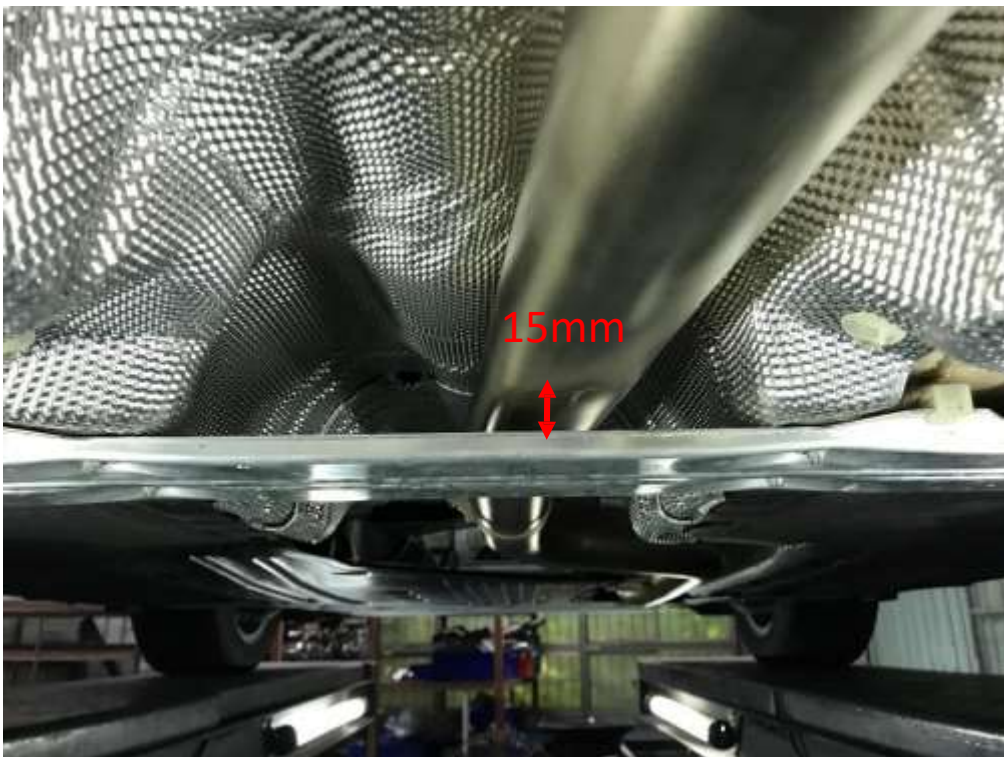
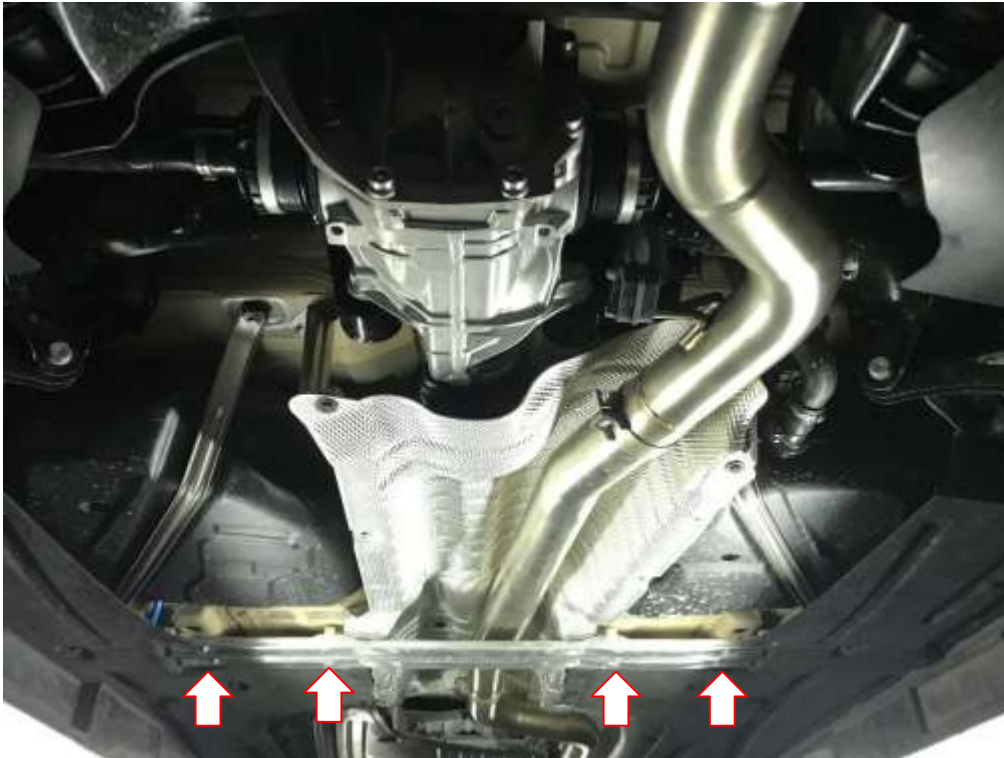

6. Install link pipe and hangers, **DO NOT** tight down the V-clamp now.



7. Install the muffler and hangers, **DO NOT** tight down the V-clamp now.



8. Install the exit pipes and tips, make sure there is **10-15mm** between exhaust and under chassis.
9. Tight down all V-clamps from the downpipe to mufflers.



Install the controlling box and wiring

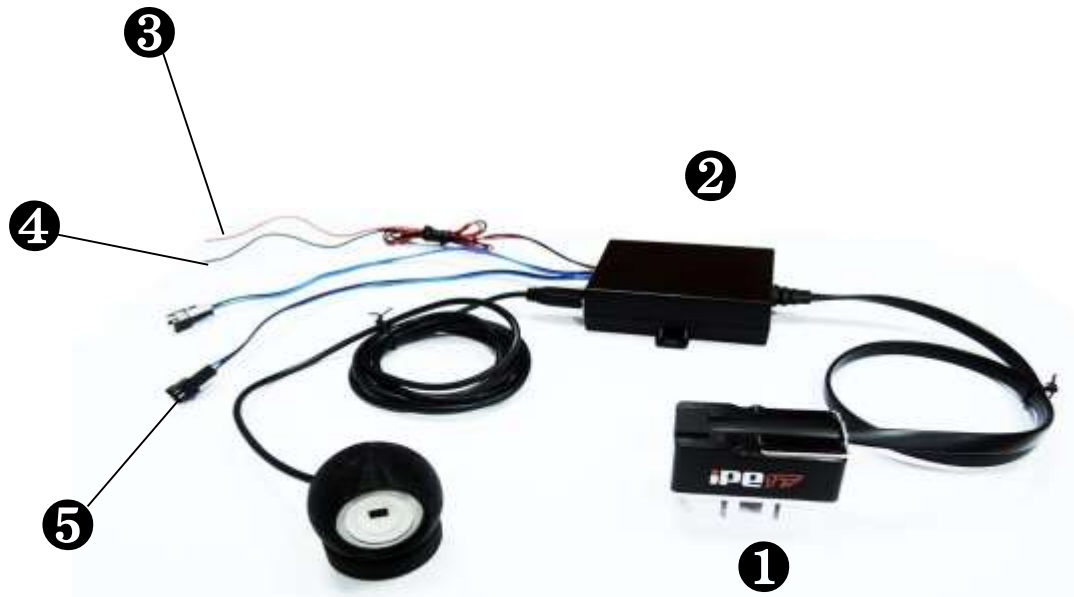

No.	Item	No.	Item
1	OBD2 connector	4	Negative (black)
2	Solenoid valve controller	5	Blue and Black (solenoid valve)
3	Positive (Red)	6	

From the fuse box on the right rear of the trunk, measure the ACC positive electricity and pull it under the driver's seat.



Plug in the electronic motor plug, and pull the OBD II one-to-two extension cable to the front left.



Pull from the front left chassis to the driver's seat.



The driver's seat removes the interior trim panel, lifts the carpet, pulls out the electronic motor cable, and connects the negative ground. After the wiring is completed, restore the parts and connect the OBD II to complete the installation.



Put back all the under cover

